

REV LTR	DESCRIPTION	DATE	APPVD.
-	Orig. Release	11/15/23	MLG

XE643S – R00
HC/ACMOS OSCILLATORS
FOR SPACE & HI-REL APPLICATIONS
450 KHz to 125 MHz
(7 x 9 mm, Straight Leads, 1.8V)

(Refer to Page 5 for Alternate Models with Reduced Screening & QCI)

REV STATUS OF SHEETS	REV																
	SHEET NO.	1	2	3	4	5	6	7	8	9	10	11	12	13	14	15	16
APPROVALS	DATE	XSIS ELECTRONICS, INC.															
PREP. N. Gupta	11/15/23	12620 W. 63 rd Street, Shawnee, KS 66216 USA															
ENG. M. Gupta	11/15/23	XE643S-R00 HC/ACMOS "S" LEVEL OSCILLATORS															
Q. A. S. Gupta	11/15/23	FSC NO.							DWG. NO.								
CUST. ENG.		57051							XE643S – R00								
CUST Q A.		SCALE							SHEET 1 OF 9								
		N/A															

1. SCOPE:

XE643S-R00 Series, HC/ACMOS, high reliability hybrid microcircuit crystal oscillators are designed, produced and tested by Xsis Electronics, Inc. as MIL-PRF-55310, Class "S" equivalent devices for use in high reliability industrial, military, avionics and space applications. These devices are of hybrid microcircuit technology conforming to MIL-PRF-55310, Type 1, Class 2 oscillators.

1.1 ALTERNATE MODELS: Models XE643E, XE643B and XE643P, with reduced QCI and/or reduced screening and shorter lead times are also offered as explained on page 5.

2. APPLICABLE DOCUMENTS:

MIL-PRF-55310F Oscillator, Crystal Controlled, General Specifications for
MIL-PRF-38534K Hybrid Microcircuits, General Specifications for
MIL-STD-883L Test Methods and Procedures for Microelectronics

3. REQUIREMENTS:

3.1 General: The individual item requirements shall be as specified herein.

3.2 Package: Ceramic, 90% Min. AL₂O₃, Weight 0.60 g Max., Thermal Resistance, θ_{JC} : 28°C / Watt.

3.2.1 Lead finish: 50 to 70 micro-inches gold over 100 to 250 micro-inches nickel. Hot Solder tinning with Sn63/Pb37 solder per MIL-PRF-55310 is optional at an additional cost.

3.2.2 Reflow Soldering: Reflow soldering at 260°C for 10 seconds shall not degrade the performance.

3.3 Hermeticity: Resistance welded, hermetically sealed, leak rate of $1 \times (10)^{-8}$ atm-cc/s Max.

3.4 Marking: As a minimum, the parts shall be marked with Xsis P/N, ESD symbol, date code and serial number.

3.5 Absolute Maximum Ratings: Unless otherwise specified, absolute maximum ratings shall be as follows:

Supply Voltage	-0.5 to +4 VDC
Operating Free-Air Temperature Range	-55°C to +125°C
Storage Temperature	-55°C to +125°C

3.6 Electrical Characteristics: See Table I

3.6.1 Total Dose Radiation: The Hybrid Microcircuit Crystal Oscillators shall be capable of meeting the electrical characteristics of Para. 3.6 after being exposed to total ionizing dose radiation of 100 krads as per MIL-STD-883, method 1019.

3.7 Hybrid Elements:

3.7.1 Quartz Crystals: A high-grade cultured quartz crystal shall be used. As an option, Xsis will use premium Q swept quartz crystal at an additional charge, refer to part numbering example in paragraph 6 to specify swept quartz crystal. Crystal element evaluation shall be in accordance with MIL-PRF-55310.

3.7.2 Crystal Mounting: The Crystal element shall be mounted at 4 points in such a manner as to provide adequate ruggedness and performance under extreme environments specified herein.

3.7.3 Passive Elements: Established Reliability (ER) QPL components, failure level R minimum shall be used or element lot evaluation shall be as per MIL-PRF-55310, class S, or MIL-PRF-38534, Appendix C, Class K as applicable.

XSIS ELECTRONICS, INC.

12620 W. 63rd St., Shawnee, KS 66216 USA

Tel: 913-631-0448 e-mail: xsis@xsis.com website: www.xsis.com

FSC NO.

57051

DWG. NO.

XE643S-R00

REV

SCALE

N/A

SHEET

2 OF 9

- 3.7.4 The Microcircuit die shall be from lots that have passed element evaluation per MIL-PRF-55310, Appendix B, Level S, except testing per Subgroup 5 is omitted. Subgroup 5 testing is circuit configuration dependent, therefore, it is more effectively performed at the oscillator level as explained in Paragraph 3.7.5.
- 3.7.5 For Output Frequencies up to 16 MHz the microcircuit die shall be from NSC/FC 54ACT family. For higher output frequencies, the microcircuit die shall be from CMOS or BiCMOS Si family from NPC. The Microcircuit die shall be from wafer lots that have been successfully tested in the oscillator for ionizing radiation up to 100 krads. Xsis Electronics has also performed SET & SEL testing on both types of microcircuit die stated above. Both die are SEL immune for LET of up to 95 Mev-cm²/mg. Test reports are available on request.
- 3.7.6 Workmanship: Assembly, Rework and Process controls shall be in accordance with the requirements of MIL-PRF-55310 & MIL-PRF-38534 as applicable.
- 3.7.7 Lot Traceability: Production lot for these oscillators shall be homogenous. Each element used in the production lot shall be traceable to a single lot. Swept quartz shall be traceable to the quartz bar, and its applicable processing details.
- 3.7.8 Prohibited Materials: The following items shall not be used in these oscillators: Pure Tin (Sn >97%), Cadmium, Zinc, Mercury, Selenium, Silver as under plate, and Gold Plating without a nickel barrier.
- 3.7.9 Element Derating: All active and passive elements shall be derated in accordance with the applicable Hybrid microcircuit requirements of MIL-STD-975. Elements shall not operate in excess of derated values.
- 3.7.10 Material Outgassing: All materials shall meet a TML of 1% Max. and a CVCm of 0.1% Max., when tested in accordance with ASTM E595.
4. QUALITY ASSURANCE PROVISIONS: The quality assurance provisions shall be as specified herein.
- 4.1 100% Screening: The 100% screening shall be performed as per Table II. In addition, MIL-PRF-38534 Group B Option 1 in-line inspection for bond strength and die shear shall be performed at pre-seal inspection. PDA requirements for nondestructive bond pull and burn-in shall be as specified below.
- 4.2 PDA for Nondestruct Bond Pull: Unless otherwise specified, PDA shall be 2% of total number of wires or one wire, whichever is greater.
- 4.3 PDA for Burn-in: Unless otherwise specified, PDA for burn-in shall be 2% or one oscillator, whichever is greater, and shall be applicable to +23°C and/or +25°C static tests only. In addition, Delta Calculations shall be performed after Burn-in and shall count for PDA. All measured values for Delta Calculation shall be recorded. Parts that exceed the specified delta limits shall be rejected and be counted for PDA. Delta Calculations shall be performed at 1.8 VDC for the following parameters:
- | | |
|-------------------|---------------------|
| Input Current | 10% change Maximum |
| Output High Level | 10% change Maximum |
| Output Low Level | 0.1V change Maximum |
- 4.4 Group A inspection shall be in accordance with MIL-PRF-55310 for product level S.
- 4.5 Group B inspection (30 day aging) shall be in accordance with MIL-PRF-55310 for product level S. In order to expedite delivery, by customer request, the aging test can be ended after 15 days if the amount of frequency aging is less than 50% of the 30 day specification limit.
- 4.6 Oscillators shall be capable of meeting group C inspection per MIL-PRF-55310. Generic group C inspection data on similar parts may be used to satisfy this requirement. When specified by the Customer, Xsis Electronics will perform Group C testing at an additional charge.

XSIS ELECTRONICS, INC. 12620 W. 63 rd St., Shawnee, KS 66216 USA Tel: 913-631-0448 e-mail: xsis@xsis.com website: www.xsis.com	FSC NO. 57051	DWG. NO. XE643S-R00	REV
	SCALE N/A	SHEET 3 OF 9	

4.7 Inspection and Test Data: Unless otherwise specified in the purchase order, the following Inspection and test data documentation shall be supplied with the parts.

(See Page 5 for the description of the Model Numbers other than XE643S)

Model XE643S:

Certificate of Conformance
Summary of Screening Test Results per Table II
PDA Calculations for Non-Destruct Bond Pull and Burn-in
Summary of Elements Lot Traceability
Electrical Tests before and after Burn-in
Group A Inspection Summary
Group B (30 day Aging) Data
Radiographic Inspection Certificate

Model XE643E:

Certificate of Conformance
Summary of Screening Test Results per Table III
Summary of Elements Lot Traceability
Group A Inspection Summary
Radiographic Inspection Certificate

Model XE643B:

Certificate of Conformance
Summary of Screening Test Results per Table III
Group A Inspection Summary
Radiographic Inspection is not applicable, unless required by the Purchase Order, at additional cost.

Model XE643P:

Certificate of Conformance

4.8 The following test and inspection options are available upon customer request, at additional cost.

Customer Source Inspection for Pre-Cap and Final
Group C Inspection per MIL-PRF-55310 on 4 or 8 units
DPA (Destructive Physical Analysis)
Life Test per MIL-STD-883, Method 1005, 1000 Hrs. at +125°C
MIL-PRF-38534, Group B Inspection
MIL-PRF-38534, Group C Inspection

5. PRESERVATION, PACKAGING AND PACKING:

The oscillators shall be clean, dry and packaged in a manner to provide adequate protection against electrostatic discharge, corrosion, deterioration and physical damage during shipment.

XSIS ELECTRONICS, INC. 12620 W. 63 rd St., Shawnee, KS 66216 USA Tel: 913-631-0448 e-mail: xsis@xis.com website: www.xsis.com	FSC NO. 57051	DWG. NO. XE643S-R00	REV
	SCALE N/A	SHEET 4 OF 9	

6. PART NUMBERING EXAMPLE:

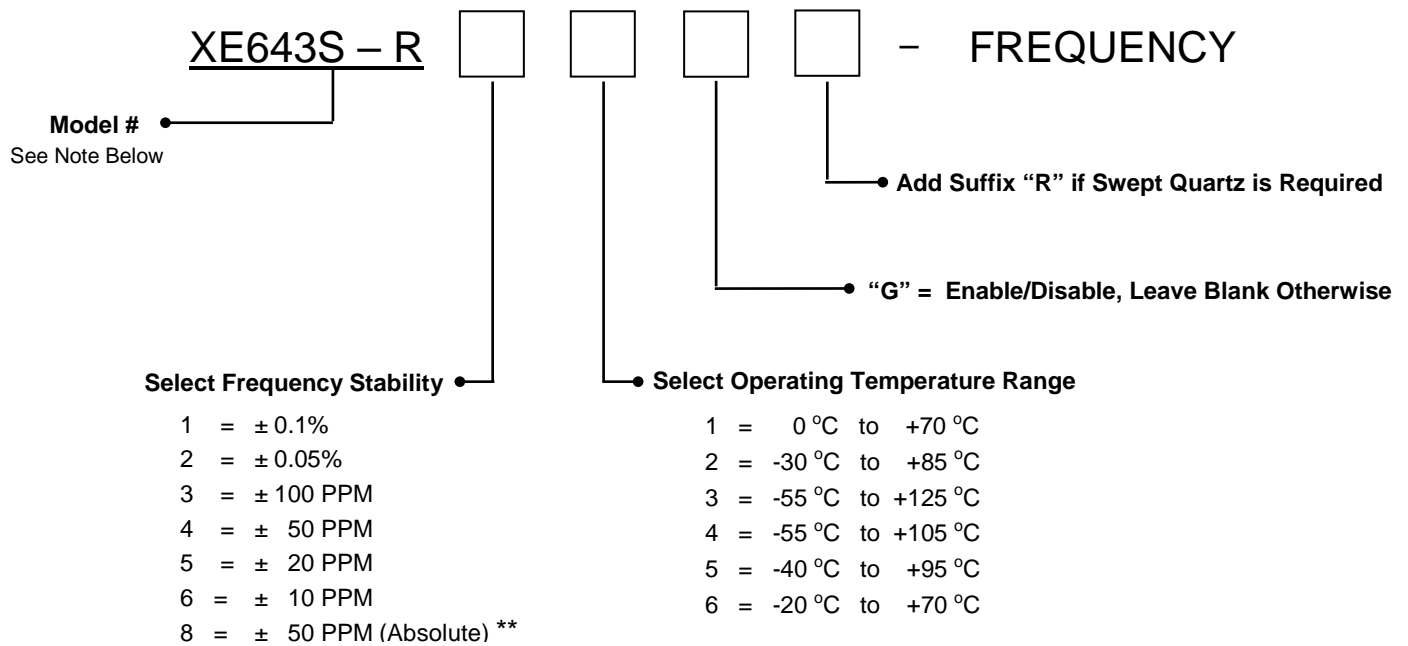

** Option 8 provides ± 50 PPM frequency-temperature stability referenced to the specified nominal frequency including load & supply voltage variations of ± 10%.

(Frequency Stability Options 5 & 6 are not available for all Temperature Range Options)

P/N Example: XE643S - R43 - 24.000 MHz = 24.000 MHz, 1.8V Oscillator, ± 50 PPM Frequency Stability over an operating temperature range of -55 °C to +125 °C.

NOTE: Besides model **XE643S**, the following additional models are available for applications that can accommodate reduced level of screening and quality conformance inspection:

XE643E: Model **XE643E** uses the same design and elements as Model **XE643S** except as follows:

- 100% screening is as per Table III herein
- PDA for Burn-in is 10% or 1 unit whichever is greater
- Delta measurements of paragraph 4.3 are not applicable
- Group A inspection is as per MIL-PRF-55310, Class B
- Group B inspection (30 day aging) per MIL-PRF-55310 is not applicable

XE643B: Model **XE643B** is same as Model **XE643E** except as follows:

- Active and Passive Elements are as per MIL-PRF-55310, Class B. The Microcircuit die is the same as in Model **XE643S** but is not from a radiation tested wafer lot.
- Radiographic Inspection is not applicable, unless required by the Purchase Order at additional cost.

XE643P: Model **XE643P** is a form, fit and function equivalent prototype of Model **XE643S**.

- Prototypes may use commercial grade elements and are not screened.
- Quality Conformance inspection is not applicable

XSIS ELECTRONICS, INC. 12620 W. 63 rd St., Shawnee, KS 66216 USA Tel: 913-631-0448 e-mail: xsis@xisis.com website: www.xsis.com	FSC NO. 57051	DWG. NO. XE643S-R00	REV
	SCALE N/A	SHEET 5 OF 9	

7. PACKAGE OUTLINE:

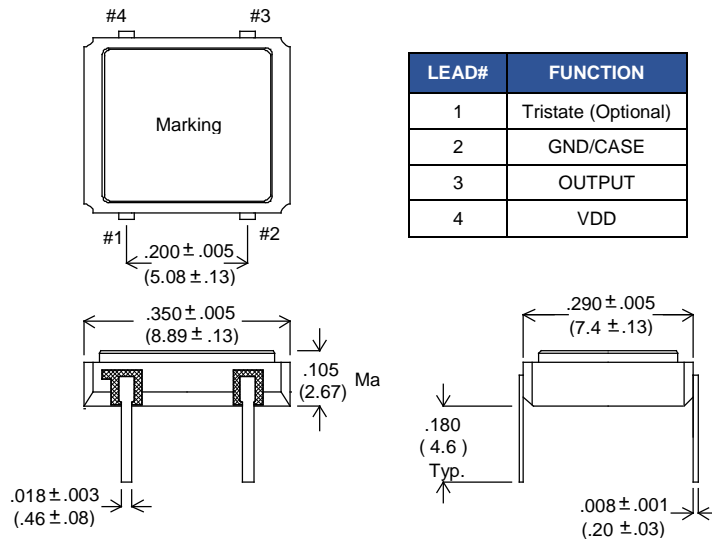

Figure 1 - Package Configuration & Pin Connections

Table I - Electrical Characteristics

Parameter	Spec. Limits
Frequency Range	450 KHz to 125 MHz
Input Voltage	+ 1.8 VDC \pm 10%
Absolute Max. Applied Voltage	+ 4.0 VDC
Frequency Accuracy at 23°C	\pm 15 PPM Max.
Frequency Stability vs. Temperature	See Options in Paragraph 6.0
Operating Temperature Range	See Options in Paragraph 6.0
Input Current at 1.8V (no load)	
450 KHz - 5 MHz	2.0 mA Max.
5 MHz - 10 MHz	2.5 mA Max.
10 MHz - 16 MHz	3.0 mA Max.
16 MHz - 30 MHz	6.0 mA Max.
30 MHz - 55 MHz	10.0 mA Max.
55 MHz - 70 MHz	20.0 mA Max.
70 MHz - 125 MHz	30.0 mA Max.
Output Waveform	Square Wave, HC/ACMOS
Output Duty Cycle (at 50% Output Levels)	55/45% Max
Output Load	10K 15 pF
High Output Level	0.9 VDD Min.
Low Output Level	0.1 VDD Max.
Tristate (Option G)	\geq 0.7 Vdd or Open:Normal Output, \leq 0.3 Vdd:High Impedance
Rise & Fall Times (at 10 to 90% Output Levels)	
450.00 KHz to 16.00 MHz	10 nS Max.
16.01 MHz to 55.00 MHz	5 nS Max.
55.01 MHz to 125.00 MHz	3 nS Max.
Start-up Time	10 mS Max.
Phase Jitter	0.5 pS rms typ, (10 KHz to 20 MHz Integrated)
Frequency Stability Vs. Voltage	\pm 4 PPM Max for \pm 10% change in Supply Voltage
Frequency Aging @ 70°C	\pm 1.5 PPM Max. / 30 days, \pm 5 PPM Max. First Year, \pm 2.5 PPM Max. / Year thereafter

Contact Xsis Engineering for any other special requirements.

XSIS ELECTRONICS, INC. 12620 W. 63 rd St., Shawnee, KS 66216 USA Tel: 913-631-0448 e-mail: xsis@xisis.com website: www.xsis.com	FSC NO. 57051	DWG. NO. XE643S-R00	REV
	SCALE N/A	SHEET 7 OF 9	

Table II - Model XE643S Screening (100%)

Test - Inspection	Test Method - Condition
Nondestructive Bond Pull	MIL-STD-883, Method 2023
Internal Visual	MIL-STD-883, Method 2017, Level S
Stabilization Bake (Prior to Seal) <u>1/</u>	MIL-STD-883, Method 1008, Condition C (+150 °C) 48 hours minimum
Random Vibration	MIL-STD-883, Method 2026, Condition I - B
Thermal Shock	MIL-STD-883, Method 1011, Condition A
Temperature Cycling	MIL-STD-883, Method 1010, Condition C
Constant Acceleration	MIL-STD-883, Method 2001, Condition A Y ₁ axis only (5000 G)
Seal (Fine and Gross Leak)	MIL-PRF-55310, Para. 4.8.2.2.3
Particle Impact Noise Detection (PIND)	MIL-STD-883, Method 2020, Condition A
Radiographic Inspection	MIL-STD-883, Method 2012, Class S
Pre Burn-in Electrical Tests: Record as applicable	Refer to Table II-a below
Burn-in	+125 °C, Nominal Supply Voltage and Burn-in load 320 Hours Minimum
Post Burn-in Electrical Tests: Record as applicable	Refer to Table II-a below
External Visual	MIL-STD-883, Method 2009

1/ Vacuum bake and maintain oscillators in dry nitrogen per MIL-PRF-55310.

Table II-a - Pre & Post Burn-in Electrical Tests

Test Parameter	MIL-PRF-55310 Method	Pre BI 24 ± 1 °C	Post BI 24 ± 1 °C	Post BI Low Temp	Post BI High Temp
Input Current	4.8.5	✓	✓	✓	✓
Output Frequency	4.8.6	✓	✓	✓	✓
Frequency Vs. Temperature Stability	4.8.10.1	✓	✓	✓	✓
Frequency Vs. Supply Voltage	4.8.14	✓	✓	✓	✓
Output Voltage Levels	4.8.21.3	✓	✓	✓	✓
Output Rise & Fall Times	4.8.22	✓	✓	✓	✓
Output Duty Cycle	4.8.23	✓	✓	✓	✓
Start-up time	4.8.29	✓	✓	✓	✓
Tristate, if applicable	4.8.28	✓	✓	✓	✓

XSIS ELECTRONICS, INC. 12620 W. 63 rd St., Shawnee, KS 66216 USA Tel: 913-631-0448 e-mail: xsis@xsis.com website: www.xsis.com	FSC NO. 57051	DWG. NO. XE643S-R00	REV
	SCALE N/A	SHEET 8 OF 9	

Table III - Models XE643E & XE643B, Screening (100%)

Test - Inspection	Test Method - Condition
Nondestructive Bond Pull	MIL-STD-883, Method 2023
Internal Visual	MIL-STD-883, Method 2017, Level B
Stabilization Bake (Prior to Seal) <u>1/</u>	MIL-STD-883, Method 1008, Condition C (+150°C) 24 hours minimum
Temperature Cycling	MIL-STD-883, Method 1010, Condition B
Constant Acceleration	MIL-STD-883, Method 2001, Condition A Y ₁ axis only (5000 G)
Seal (Fine and Gross Leak)	MIL-PRF-55310, Para. 4.8.2.2.2
Particle Impact Noise Detection (PIND)	MIL-STD-883, Method 2020, Condition A
Radiographic Inspection (Model XE643E Only) <u>2/</u>	MIL-STD-883, Method 2012, Class S
Pre Burn-in Electrical Tests: Record as applicable	Refer to Table III-a below
Burn-in	+125 °C, Nominal Supply Voltage and Burn-in load 160 Hours Minimum
Post Burn-in Electrical Tests: Record as applicable	Refer to Table III-a below
External Visual	MIL-STD-883, Method 2009

1/ Vacuum bake and maintain oscillators in dry nitrogen per MIL-PRF-55310

2/ Radiographic Inspection is applicable to Model XE643E only

Table III-a - Pre & Post Burn-in Electrical Tests

Test Parameter	MIL-PRF-55310 Method	Pre BI 24 ± 1 °C	Post BI 24 ± 1 °C	Post BI Low Temp	Post BI High Temp
Input Current	4.8.5	✓	✓	✓	✓
Output Frequency	4.8.6	✓	✓	✓	✓
Frequency Vs. Temperature Stability	4.8.10.1	✓	✓	✓	✓
Frequency Vs. Supply Voltage	4.8.14	✓	✓	✓	✓
Output Voltage Levels	4.8.21.3	✓	✓	✓	✓
Output Rise & Fall Times	4.8.22	✓	✓	✓	✓
Output Duty Cycle	4.8.23	✓	✓	✓	✓
Start-up time	4.8.29	✓	✓	✓	✓
Tristate, if applicable	4.8.28	✓	✓	✓	✓

XSIS ELECTRONICS, INC.
12620 W. 63rd St., Shawnee, KS 66216 USA
 Tel: 913-631-0448 e-mail: xsis@xsis.com website: www.xsis.com

FSC NO.
57051

DWG. NO.
XE643S-R00

REV

SCALE N/A

SHEET 9 OF 9