



# XC5R SERIES ( HC/ACMOS ), 1.8 VDC TRISTATE 5 x 7 mm, SMD

## FEATURES:

- Wide Frequency Range
- Excellent Jitter Performance
- Military Screening Tests Available

## APPLICATIONS::

- Optical Networking, SONET/SDH
- Broadband Data Transmission
- High Shock & Vibration Environments

Frequency Range 1.0 MHz to 160 MHz  
 Frequency Accuracy Over Operating Temperature See Options Below  
 Operating Temperature Range See Options Below  
 Storage Temperature Range -62 °C to +125 °C

Input Voltage + 1.8 VDC ± 10%  
 Input Current @ +1.8 VDC (No Load )  
 1.0 MHz to 8.0 MHz 2 mA Max.  
 8.1 MHz to 32.0 MHz 4 mA Max.  
 32.1 MHz to 64.0 MHz 15 mA Max.  
 64.1 MHz to 100.0 MHz 25 mA Max.  
 100.1 MHz to 160.0 MHz 50 mA Max.

Output HC/ACMOS Compatible  
 Output Load 15 pf // 10K  
 High Level 0.9 V<sub>DD</sub> Min.  
 Low Level 0.1 V<sub>DD</sub> Max.  
 Symmetry @ 50% Level 60/40% ( 55/45% Optional )  
 Rise & Fall Times ( 20% to 80% of Output )  
 ≤ 40 MHz 6 nS Max.  
 40.0 to 70.0 MHz 5 nS Max.  
 70.1 to 160 MHz 3 nS Max.

Enable / Disable Input Function  
 Open or High ( ≥ 0.7 V<sub>CC</sub> ) Normal Output  
 Low ( ≤ 0.3 V<sub>CC</sub> ) Output disabled into a HI-Z state

Start-Up Time 10 mS Max.  
 Phase Jtter (RMS, 10 KHz to 20 MHz Integrated ) 0.3 pS Typical

Aging @ +25 °C ± 0.0005% ( ± 5 PPM ) / year Max.

Package – Seal Hermetic, Conforms to MIL-PRF-55310  
 Pad Finish 0.3 μm Min. gold plate over Nickel  
 Solder Reflow Temp/Time 260 °C Max for 10 Seconds Max.

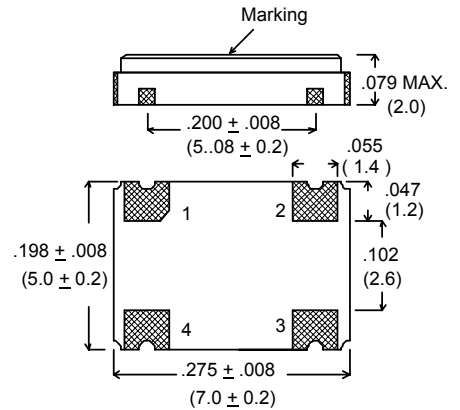

Dimensions are in inches (mm)  
 All dimensions are typical unless otherwise specified

Pad #	Function
1	E/D
2	GND
3	OUTPUT
4	V <sub>DD</sub>

An External 0.01uF Bypass Capacitor is required between VDD and GND.

**Contact Xsis Engineering for special requirements such as, Output Symmetry, Start-up Time, Frequency Accuracy, Complementary Outputs, Multiple Outputs, etc.**

## ORDERING INFORMATION ( Select from options below ) :



### Frequency Accuracy Options

- 1 = ± 50 PPM -10 °C to +70 °C
- 2 = ± 25 PPM -10 °C to +70 °C
- 3 = ± 100 PPM -40 °C to +85 °C
- 4 = ± 50 PPM -40 °C to +85 °C
- 5 = ± 25 PPM -40 °C to +85 °C
- 6 = ± 100 PPM -55 °C to +125 °C
- 7 = ± 75 PPM -55 °C to +125 °C
- 8 = ± 20 PPM -40 °C to +85 °C

### Symmetry Options

- A = 60/40%
- B = 55/45%

### Screening Options

- X = No Screening
- M = 100% Screening

**Example: XC5R - 6AM - 24.000 MHz = HC/ACMOS, 1.8 V, Tristate Output, 60/40% Symmetry ± 100 PPM Frequency Accuracy Over -55°C to +125 °C, 100% Screened**