

REV LTR	DESCRIPTION	DATE	APPVD.
A	Revised Scope. Updated frequency range. Revised paragraphs related to Hybrid Elements. Changed frequency Vs. supply voltage specification.	10/21/10	MLG
B	Updated per ECN 2012-9	12/15/11	MLG
C	Updated per ECN 2012-19	8/15/12	MLG
D	Updated per ECN 2013-4	2/21/13	MLG
E	Updated per ECN 2013-12	10/25/13	MLG
F	Updated per ECN 2016-24	12/15/16	SPG
G	Revised Scope, Added Random Vibration in Table II	11/20/20	SPG
H	Revised per ECN 2022-1	3/15/22	SPG

**XE61S - A00 SERIES**  
**HC/ACMOS OSCILLATORS**  
**FOR SPACE & HI-REL APPLICATIONS**  
**125 Hz to 90 MHz**  
**( 4 PIN DIP, 5.0V )**

For Other Supply Voltages and Package Configurations Contact Factory or visit our website [www.xsis.com](http://www.xsis.com)

( Refer to Page 5 for Reduced QCI Models XE61E, XE61B & XE61P )

REV STATUS OF SHEETS	REV SHEET NO.	1	2	3	4	5	6	7	8	9	10	11	12	13	14	15	16
APPROVALS	DATE	<b>XSIS ELECTRONICS, INC.</b>															
PREP. S. Gupta	8/10/10	12620 W. 63 <sup>rd</sup> Street, Shawnee, KS 66216 USA															
ENG. M. Gupta	8/10/10	<b>XE61S - A00 SERIES HC/ACMOS</b>															
Q. A. M. Gupta	8/10/10	<b>"S" LEVEL OSCILLATORS</b>															
CUST. ENG.		FSC NO. 57051						DWG. NO. XE61S-A00									
CUST Q A.		SCALE N/A						SHEET 1 OF 9									

1. SCOPE: XE61S-A00, HC/ACMOS series, high reliability hybrid microcircuit crystal oscillators are designed, produced and tested by Xsis Electronics, Inc. as MIL-PRF-55310, Class "S" equivalent devices for use in advanced industrial, military, avionics and space applications. These devices are of hybrid microcircuit technology conforming to MIL-PRF-55310, Type 1, Class 2 oscillators.

1.1 ALTERNATE MODELS: Alternate models, XE61E, XE61B and XE61P with reduced QCI and/or reduced screening and shorter lead times are also offered as explained on page 5.

2. APPLICABLE DOCUMENTS:

MIL-PRF-55310F	Oscillator, Crystal Controlled, General Specifications for
MIL-PRF-38534K	Hybrid Microcircuits, General Specifications for
MIL-STD-883L	Test Methods and Procedures for Microelectronics

3. REQUIREMENTS:

3.1 General: The individual item requirements shall be as specified herein.

3.2 Package: Kovar, 100 to 250 microinches nickel plated. Physical configuration as shown in Figure 1. Weight: 5 Gms Max., Thermal Resistance,  $\theta_{JC}$ : 30 °C / Watt.

3.2.1 Lead finish: 50 to 70 micro-inches gold over 100 to 250 micro-inches nickel. Hot Solder tinning with Sn60/Pb40 solder per MIL-PRF-55310 is optional at an additional cost.

3.3 Hermeticity: Resistance welded, hermetically sealed, leak rate of 1(10)<sup>-8</sup> atm-cc/s Max.

3.4 Marking: As a minimum, the parts shall be marked with Xsis P/N, Xsis cage code, ESD symbol, date code and serial number.

3.5 Absolute Maximum Ratings: Unless otherwise specified, absolute maximum ratings shall be as follows:

Supply Voltage	-0.5 to +7 VDC
Operating Free-Air Temperature Range	-55°C to +125°C
Storage Temperature	-55°C to +125°C
Lead Soldering Temperature/Time	+250°C, 10 Seconds

3.6 Electrical Characteristics: See Table I

3.6.1 Total Dose Radiation: Hybrid Microcircuit Crystal Oscillators shall be capable of meeting the electrical characteristics of Para. 3.6 after being exposed to total ionizing dose radiation of 100 krads as per MIL-STD-883, method 1019.

3.7 Hybrid Elements:

3.7.1 Quartz Crystals: High grade cultured quartz crystal shall be used. As an option, Xsis will use premium Q swept quartz crystal at an additional charge, refer to part numbering example in paragraph 6 to specify swept quartz crystal. Crystal element evaluation shall be in accordance with MIL-PRF-55310.

3.7.2 Crystal Mounting: Crystal element shall be mounted at 4 points in such a manner as to provide adequate ruggedness and performance under extreme environments specified herein.

3.7.3 Passive Elements: Established Reliability (ER) QPL components, failure level R minimum shall be used or element lot evaluation shall be as per MIL-PRF-55310, class S, or MIL-PRF-38534, Appendix C, Class K as applicable.

**XSIS ELECTRONICS, INC.**

**12620 W. 63<sup>rd</sup> St., Shawnee, KS 66216 USA**

Tel: 913-631-0448 e-mail: xsis@xis.com website: www.xsis.com

**FSC NO.**

**57051**

**DWG. NO.**

**XE61S-A00**

**REV**

**H**

**SCALE**

**N/A**

**SHEET**

**2 OF 9**

- 3.7.4 Microcircuit die shall be from lots that have passed the element evaluation per MIL-PRF-55310, Appendix B, Level S, except testing per Subgroup 5 is omitted. Subgroup 5 testing is circuit configuration dependent, therefore, it is more effectively performed at the oscillator level as explained in Paragraph 3.7.5.
- 3.7.5 Microcircuit die used in the oscillator shall be from NSC/FC 54ACT family and shall be from wafer lot that has been successfully tested in the oscillator for ionizing radiation of up to 100 krads and is known to be Single Event Latch-up immune for LET of up to 95 Mev-cm<sup>2</sup>/mg. Xsis Electronics has also performed SET & SEL testing on the microcircuit die. Test reports are available on request.
- 3.7.6 Workmanship: Assembly, Rework and Process controls shall be in accordance with the requirements of MIL-PRF-55310 & MIL-PRF-38534 as applicable.
- 3.7.7 Lot Traceability: Production lot for these oscillators shall be homogenous. Each element used in the production lot shall be traceable to a single lot. Swept quartz shall be traceable to the quartz bar, and its applicable processing details.
- 3.7.8 Prohibited Materials: The following items shall not be used in these oscillators:  
Pure Tin (Sn >97%), Cadmium, Zinc, Mercury, Selenium, Silver as under plate, and Gold Plating without a nickel barrier.
- 3.7.9 Element Derating: All active and passive elements shall be derated in accordance with the applicable Hybrid microcircuit requirements of MIL-STD-975. Elements shall not operate in excess of derated values.
- 3.7.10 Material Outgassing: All materials shall meet a TML of 1% Max. and a CVCM of 0.1% Max., when tested in accordance with ASTM E595.

4. QUALITY ASSURANCE PROVISIONS: The quality assurance provisions shall be as specified herein.

4.1 100% Screening: The 100% screening shall be performed as per Table II. MIL-PRF-38534 Group B Option 1 in-line inspection for bond strength and die shear shall be performed at pre-seal inspection. PDA requirements for nondestructive bond pull and burn-in shall be as specified below.

4.2 PDA for Nondestruct Bond Pull: Unless otherwise specified, PDA shall be 2% of total number of wires or 1 wire whichever is greater.

4.3 PDA for Burn-in: Unless otherwise specified, PDA for burn-in shall be 2% or 1 oscillator whichever is greater and shall be applicable to +23 °C and/or +25 °C static tests only. In addition Delta Calculation shall be performed after Burn-in and shall count for PDA. All measured values for Delta Calculation shall be recorded. Parts that exceed the specified delta limits shall be rejected and be counted for PDA. Delta Calculation shall be performed at 5.0 VDC for the following parameters:

Input Current	10% change Maximum
Output High Level	10% change Maximum
Output Low Level	0.1V change Maximum

4.4 Group A inspection shall be in accordance with MIL-PRF-55310 for product level S.

4.5 Group B inspection ( 30 day aging ) shall be in accordance with MIL-PRF-55310 for product level S. In order to expedite delivery, by customer request, the aging test can be ended after 15 days if the amount of frequency aging is less than 50% of the 30 day specification limit.

4.6 Oscillators shall be capable of meeting group C inspection per MIL-PRF-55310. Generic group C inspection data on similar parts may be used to satisfy this requirement. When specified by the Customer, Xsis Electronics will perform Group C testing at an additional charge.

<b>XSIS ELECTRONICS, INC.</b> 12620 W. 63 <sup>rd</sup> St., Shawnee, KS 66216 USA Tel: 913-631-0448 e-mail: xsis@xsis.com website: www.xsis.com	FSC NO.	DWG. NO.	REV
	57051	XE61S-A00	H
SCALE	N/A	SHEET	3 OF 9

4.7 Inspection and Test Data: Unless otherwise specified in the purchase order, the following Inspection and test data documentation shall be supplied with the parts.

( See Page 5 for the description of the Model Numbers other than XE61S )

**Model XE61S:**

Certificate of Conformance  
Summary of Screening Test Results per Table II  
PDA Calculations for Non-Destruct Bond Pull and Burn-in  
Summary of Elements Lot Traceability  
Electrical Tests before and after Burn-in  
Group A Inspection Summary  
Group B (30 day Aging) Data  
Radiographic Inspection Certificate

**Model XE61E:**

Certificate of Conformance  
Summary of Screening Test Results per Table III  
Summary of Elements Lot Traceability  
Group A Inspection Summary  
Radiographic Inspection Certificate

**Model XE61B:**

Certificate of Conformance  
Summary of Screening Test Results per Table III  
Group A Inspection Summary  
Radiographic Inspection is not applicable, unless required by the Purchase Order, at additional cost.

**Model XE61P:**

Certificate of Conformance

4.8 The following test and inspection options are available at customer request, at additional cost.

Customer Source Inspection for Pre-Cap and Final  
Group C Inspection per MIL-PRF-55310 on 4 or 8 units  
DPA (Destructive Physical Analysis)  
Life Test per MIL-STD-883, Method 1005, 1000 Hrs. at +125 °C  
MIL-PRF-38534, Group B Inspection  
MIL-PRF-38534, Group C Inspection

5. PRESERVATION, PACKAGING AND PACKING: The oscillators shall be clean, dry and packaged in a manner to provide adequate protection against electrostatic discharge, corrosion, deterioration and physical damage during shipment.

<b>XSIS ELECTRONICS, INC.</b> 12620 W. 63 <sup>rd</sup> St., Shawnee, KS 66216 USA Tel: 913-631-0448 e-mail: xsis@xis.com website: www.xsis.com	<b>FSC NO.</b> 57051	<b>DWG. NO.</b> XE61S-A00	<b>REV</b> H
	<b>SCALE</b> N/A	<b>SHEET</b> 4 OF 9	

6. PART NUMBERING EXAMPLE:

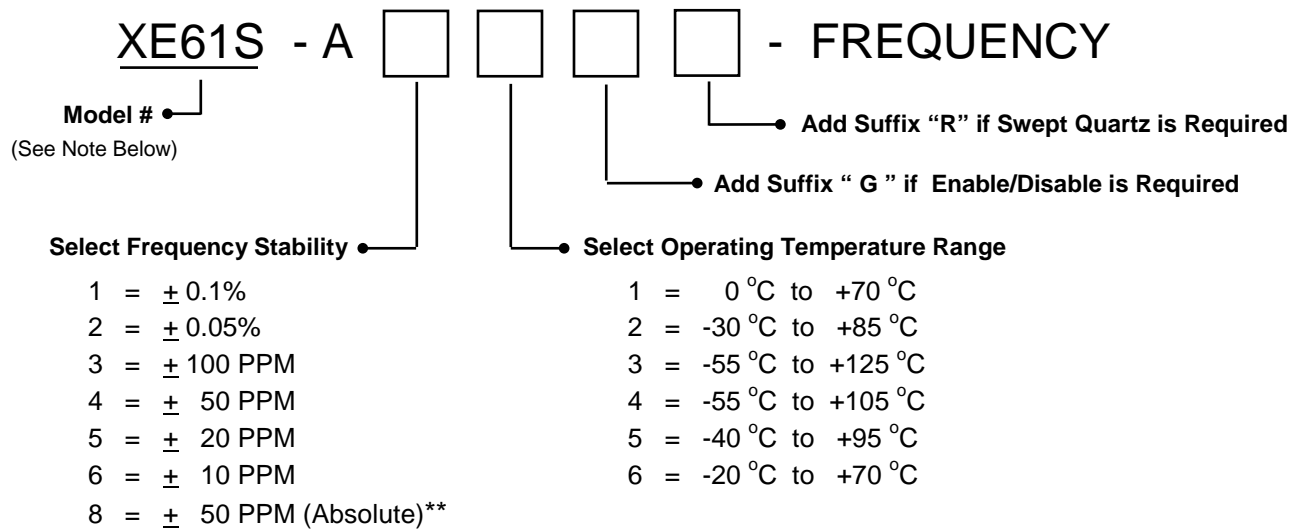

**\*\* Option 8 provides ± 50 PPM frequency-temperature stability referenced to the specified nominal frequency including load & supply voltage variations of ± 10%.**

( Frequency Stability Options 5 & 6 are not available for all Temperature Range Options )

P/N Example: XE61S - A43 - 24.000 MHz = 24.000 MHz, Class "S" Oscillator, ± 50 PPM Frequency Stability over an operating temperature range of -55 °C to +125 °C.

**NOTE:** Besides model XE61S above, the following additional models are available for applications that can accommodate reduced level of Elements, Screening and Quality Conformance inspection:

**XE61E: Model XE61E** uses the same design and elements as **Model X61S** except as follows:  
 100% screening is as per Table III herein  
 PDA for Burn-in is 10% or 1 unit whichever is greater  
 Delta measurements of paragraph 4.3 are not applicable  
 Group A inspection is as per MIL-PRF-55310, Class B  
 Group B inspection (30 day aging ) per MIL-PRF-55310 is not applicable

**XE61B: Model XE61B** is same as **Model XE61E** except as follows:  
 Active and Passive Elements are as per MIL-PRF-55310, Class B. Microcircuit die is similar to the one used in **Model XE61S** but is not from radiation tested wafer lot.  
 Radiographic Inspection is not applicable, unless required by the Purchase Order at additional cost.

**XE61P: Model XE61P** is a form, fit and function equivalent prototype of **Model XE61S**. Prototypes may use commercial grade elements and are not screened. Quality Conformance inspection is not applicable.

<b>XSIS ELECTRONICS, INC.</b> 12620 W. 63 <sup>rd</sup> St., Shawnee, KS 66216 USA Tel: 913-631-0448 e-mail: xsis@xsis.com website: www.xsis.com	FSC NO. <b>57051</b>	DWG. NO. <b>XE61S-A00</b>	REV <b>H</b>
	SCALE <b>N/A</b>	SHEET <b>5 OF 9</b>	

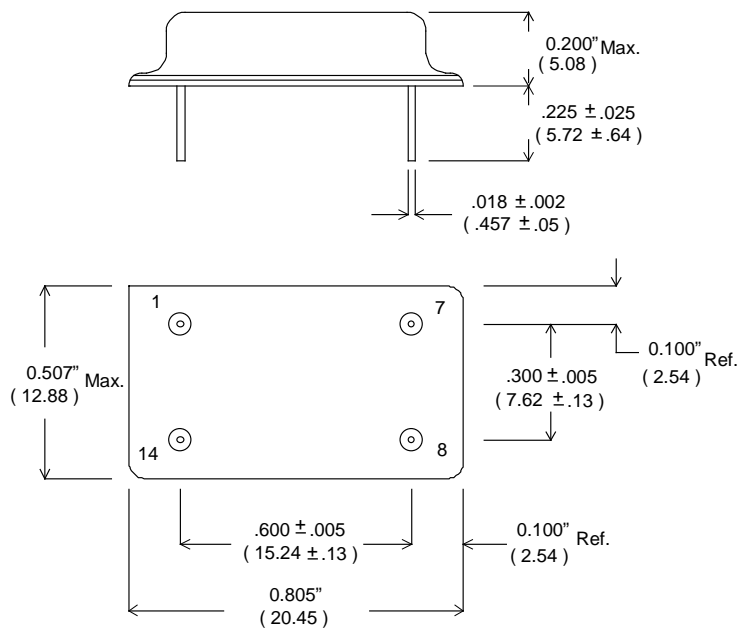

PIN #	FUNCTION
1	E/D (Optional)
7	GND/CASE
8	OUTPUT
14	B+
All Other	Missing

**E/D (Enable/Disable) Input:** A "Low" level at the input disables the Output into a high impedance state.

E/D Input has internal pull-up, it can be left floating or connected to Vdd.

Pin 1 is identified with a square corner

Dimensions: Inches (mm).

Figure 1 - Package Configuration & Pin Connections

**TABLE I – Electrical Characteristics**

Parameter	Spec. Limits
Frequency Range	125 Hz to 90 MHz
Frequency Accuracy at 23 °C	± 15 PPM Max.
Frequency Stability Vs Temperature	See Options in Paragraph 6.0
Operating Temperature Range	See Options in Paragraph 6.0
Input Voltage	+ 5 VDC ± 10%
Input Current at 5.0V ( no load )	
125 Hz to 5.00 MHz	6 mA Max.
5.01 MHz to 10.00 MHz	10 mA Max.
10.01 MHz to 20.00 MHz	20 mA Max.
20.01 MHz to 30.00 MHz	25 mA Max.
30.01 MHz to 40.00 MHz	30 mA Max.
40.01 MHz to 50.00 MHz	35 mA Max.
50.01 MHz to 90.00 MHz	50 mA Max.
Output Waveform	Square Wave, HC/ACMOS
Output Duty Cycle	55/45% Max
Output Load	10K    15 pF
High Output Level	0.9 VDD Min
Low Output Level	0.1 VDD Max.
Enable/Disable ( Option G )	≥ 2.2V or Open: Normal Output < 0.8V High Impedance
Rise & Fall Times	
125.0 Hz to 25.00 MHz	5 nS Max
25.01 MHz to 45.00 MHz	4 nS Max.
45.01 MHz to 90.00 MHz	3 nS Max.
Start-up Time	10 mS Max.
Phase Jitter	0.3 pS rms typ, (10 KHz to 20 MHz Integrated )
Frequency Stability Vs Supply Voltage	± 4 PPM Max. for 10% change in Voltage
Frequency Aging @ 70 °C	± 1.5 PPM Max. /30 days, 5 PPM Max. first year, ± 2.5 PPM Max./year thereafter

Contact Xsis Engineering for any other special requirements.

<b>XSIS ELECTRONICS, INC.</b> 12620 W. 63 <sup>rd</sup> St., Shawnee, KS 66216 USA Tel: 913-631-0448 e-mail: xsis@xsis.com website: www.xsis.com	FSC NO. <b>57051</b>	DWG. NO. <b>XE61S-A00</b>	REV <b>H</b>
	SCALE <b>N/A</b>	SHEET <b>7 OF 9</b>	

**Table II - Model XE61S Screening (100%)**

Test - Inspection	Test Method – Condition
Nondestructive Bond Pull	MIL-STD-883, Method 2023
Internal Visual	MIL-STD-883, Method 2017, Level S
Stabilization Bake ( Prior to Seal ) <u>1/</u>	MIL-STD-883, Method 1008, Condition C ( +150°C ), 48 hours minimum
Random Vibration	MIL-STD-883, Method 2026, Condition I- B
Thermal Shock	MIL-STD-883, Method 1011, Condition A
Temperature Cycling	MIL-STD-883, Method 1010, Condition C
Constant Acceleration	MIL-STD-883, Method 2001, Condition A Y <sub>1</sub> axis only ( 5000 G )
Seal ( Fine and Gross Leak )	MIL-PRF-55310, Para. 4.8.2.2.3
Particle Impact Noise Detection ( PIND )	MIL-STD-883, Method 2020, Condition A
Radiographic Inspection	MIL-STD-883, Method 2012, Class S
Pre Burn-in Electrical Tests: Record as applicable	Refer to Table II-a below
Burn-in	+125°C, Nominal Supply Voltage and Burn-in load, 320 Hours Minimum
Post Burn-in Electrical Tests: Record as applicable	Refer to Table II-a below
External Visual	MIL-STD-883, Method 2009

1/ Vacuum bake and maintain oscillators in dry nitrogen per MIL-PRF-55310

**Table II-a – Pre & Post Burn-in Electrical Tests**

Test Parameter	MIL-PRF-55310 Method	Pre BI 24 ± 1 °C	Post BI 24 ± 1 °C	Post BI Low Temp	Post BI High Temp
Input Current	4.8.5	✓	✓	✓	✓
Output Frequency	4.8.6	✓	✓	✓	✓
Frequency Vs. Temperature Stability	4.8.10.1	✓	✓	✓	✓
Frequency Vs. Supply Voltage	4.8.14	✓	✓	✓	✓
Output Voltage Levels	4.8.21.3	✓	✓	✓	✓
Output Rise & Fall Times	4.8.22	✓	✓	✓	✓
Output Duty Cycle	4.8.23	✓	✓	✓	✓
Start-up time	4.8.29	✓	✓	✓	✓
Enable/Disable, if applicable	4.8.28	✓	✓	✓	✓

**XSIS ELECTRONICS, INC.**  
**12620 W. 63<sup>rd</sup> St., Shawnee, KS 66216 USA**  
 Tel: 913-631-0448 e-mail: xsis@xis.com website: www.xsis.com

**FSC NO.**

**57051**

**DWG. NO.**

**XE61S-A00**

**REV**

**H**

**SCALE**

**N/A**

**SHEET**

**8 OF 9**



**Table III - Models XE61E & XE61B, Screening (100%)**

Test - Inspection	Test Method – Condition
Nondestructive Bond Pull	MIL-STD-883, Method 2023
Internal Visual	MIL-STD-883, Method 2017, Level B
Stabilization Bake ( Prior to Seal ) <u>1/</u>	MIL-STD-883, Method 1008, Condition C ( +150 °C ), 24 hours minimum
Temperature Cycling	MIL-STD-883, Method 1010, Condition B
Constant Acceleration	MIL-STD-883, Method 2001, Condition A Y <sub>1</sub> axis only ( 5000 G )
Seal ( Fine and Gross Leak )	MIL-PRF-55310, Para. 4.8.2.2.2
Particle Impact Noise Detection ( PIND )	MIL-STD-883, Method 2020, Condition A
Radiographic Inspection ( <b>Model XE61E Only</b> ) <u>2/</u>	MIL-STD-883, Method 2012, Class S
Pre Burn-in Electrical Tests: Record as applicable	Refer to Table III-a below
Burn-in	+125 °C, Nominal Supply Voltage and Burn-in load, 160 Hours Minimum
Post Burn-in Electrical Tests: Record as applicable	Refer to Table III-a below
External Visual	MIL-STD-883, Method 2009

1/ Vacuum bake and maintain oscillators in dry nitrogen per MIL-PRF-55310

2/ Radiographic Inspection is applicable to Model XE61E only

Table III-a – Pre & Post Burn-in Electrical Tests

Test Parameter	MIL-PRF-55310 Method	Pre BI 24 ± 1 °C	Post BI 24 ± 1 °C	Post BI Low Temp	Post BI High Temp
Input Current	4.8.5	✓	✓	✓	✓
Output Frequency	4.8.6	✓	✓	✓	✓
Frequency Vs. Temperature Stability	4.8.10.1	✓	✓	✓	✓
Frequency Vs. Supply Voltage	4.8.14	✓	✓	✓	✓
Output Voltage Levels	4.8.21.3	✓	✓	✓	✓
Output Rise & Fall Times	4.8.22	✓	✓	✓	✓
Output Duty Cycle	4.8.23	✓	✓	✓	✓
Start-up time	4.8.29	✓	✓	✓	✓
Enable/Disable, if applicable	4.8.28	✓	✓	✓	✓

**XSIS ELECTRONICS, INC.**

**12620 W. 63<sup>rd</sup> St., Shawnee, KS 66216 USA**

Tel: 913-631-0448 e-mail: xsis@xis.com website: www.xsis.com

**FSC NO.**

**57051**

**DWG. NO.**

**XE61S-A00**

**REV**

**H**

**SCALE**

**N/A**

**SHEET**

**9 OF 9**